

# DUNHAM-BUSH®

## Series CM Fan Convectors



*Products that perform... By people who care*



## Contents

### Identification

Introduction	2
Authority	2

### Description

Composition- features	2
Range	2
Accessories	2

### Performance

Heat outputs	5
Correction factors	5
Electrical data	5
Coil capacities	5
Heater masses	5

### Application

General	6
Selection	6
Dimensions	7
Engineering specification	8

### Construction

Handling	9
Storage	9
Preparation	9
Installation	10
Pipework connections	10
Electrical connections	10

### Prices & conditions of sale

Prices	10
Conditions of sale	10

### Supply

Availability	10
Packaging	10
Ordering	10
Delivery to site	10

## Identification

### Introduction

Series CM fan convectors by Dunham-Bush are the ideal heating solution for general applications such as schools, colleges, offices and libraries. They are simple in design but are built to the same robust quality that is typical of all Dunham-Bush products.

They are free-standing low-level heaters, designed to provide warm-air heating when used with low temperature hot water, with an overall height of 600mm, Series CM is well suited to under-sill or under-worktop applications.

The standard finish is a smooth polyester powder coating, with a grey satin finish, and grilles finished in black. Accessories include automatic temperature control, as well as user controls which can be fitted or remote. Grilles are 'pencil-proof' to minimise the ingress of debris, and access panels are lockable to prevent tampering with the heater or its settings.

### Authority

It is accepted practice at Dunham-Bush to maintain exceptional standards in engineering and quality. To this end, Dunham-Bush operates a quality system and is registered as a company of assessed capability to BS EN ISO 9001 : 2000

## Description

### Composition

Each Series CM fan convector comprises a free standing sheet metal casing fitted with extruded aluminium alloy, pencil proof grilles and lockable access panel. The casing contains a fan /motor platform, auto transformer, air filter and hot water heating coil.

Heaters are supplied for single or dual fan speed operation. Single speed heaters are set to low, medium or high speed. Dual speed heaters are set to low/medium, low/high or medium/high speeds. Fan control is by means of switches and/or air thermostats, listed in the Accessories section of this Product Catalogue.

### Range

The range consists of two models.

Model SA standard air flow, bottom front inlet and top front outlet.

Model RA reversed air flow, top front inlet and bottom front outlet.

Both models are offered in a range figure numbers, which relate to the heat output and length, as shown below.

Table 1:

Figure number	Nominal output kW	Casing length mm
3	2.6	695
4	4.7	895
6	6.0	895
8	8.2	1195
10	9.4	1195
12	11.4	1495
15	12.7	1495



# Composition - features

Image 1:

Model SA figure number 4 (left hand connections)

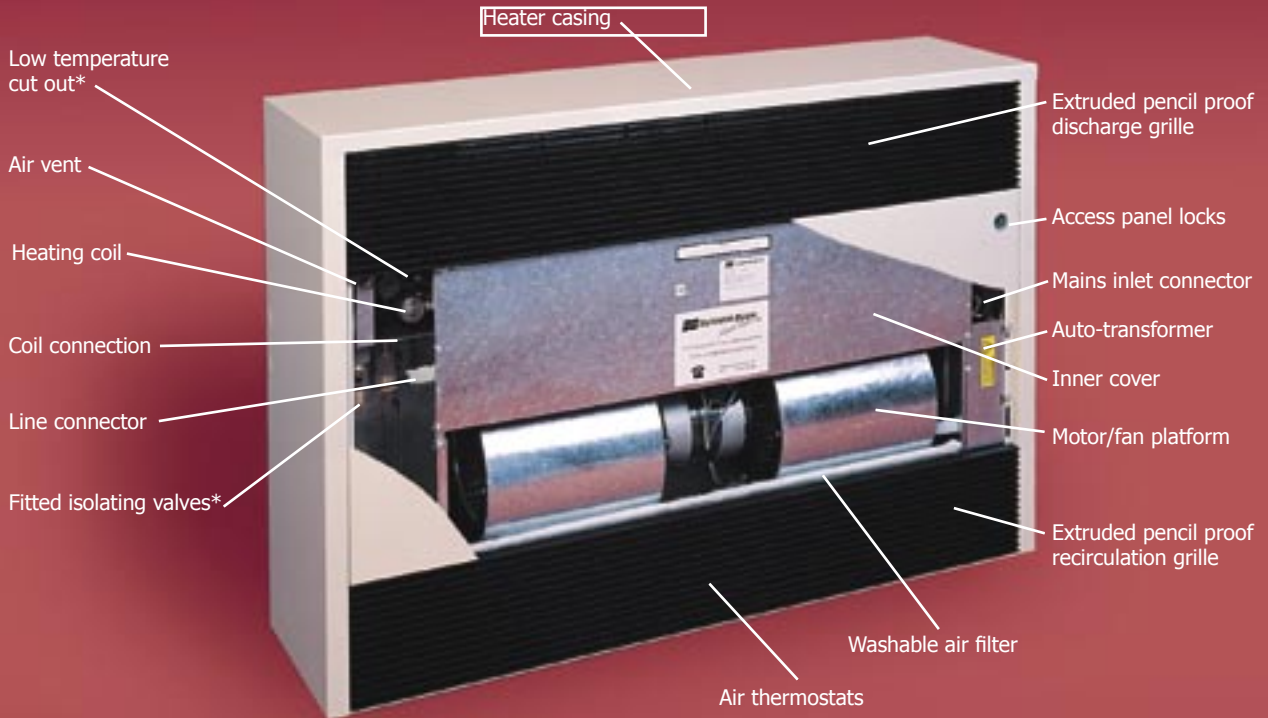

Items marked \* are accessories



Model RA figure number 4 (left hand connections)

## Accessories

### Air thermostats

Air thermostats can be provided to automatically switch the heater on/off and to change the fan speed/heat output, in response to a fall or rise in ambient air temperature.

#### *Fitted air thermostats – Model SA only*

Capillary thermostats can be fitted for on/off and speed change.

#### *Remote thermostats*

Standard or tamper resistant room thermostats can be provided for on/off and speed change.

### Low-limit thermostat

A low limit thermostat can be provided to prevent the heater operating until the heating water temperature is hot enough for it to work efficiently. This thermostat will automatically stop the heater at the end of the normal operating period, when the boiler plant closes down.

*Type 1*, fixed setting low limit thermostat, break circuit @  $43^{\circ}\text{C}\pm 3\text{K}$ , make circuit @  $54^{\circ}\text{C}\pm 3\text{K}$ .

If fitted, Type 1 is wired into the control circuit and clamped to the coil tube nearest to the LTHW flow connection.

*Type 2*, adjustable setting low limit thermostat, range 30 to  $90^{\circ}\text{C}$ .

If supplied, Type 2 is wired into the control circuit and stored inside of the heater casing, for clamping to the LTHW flow pipe by the installer.

### Switches

Fitted external or remote switches can be provided to switch the heater on/off, to change speed, to allow thermostats to work automatically and to override any thermostats. The override "manual" switch allows the fans to circulate room air when the boiler plant is shut down during the summer.

#### *Fitted switches*

1. On/off, 2. High/off/low, 3. Manual/off/auto, 4. Manual/off/auto and high/low.

#### *Remote switches-surface or flush mounting*

1. On/off, 2. High/off/low, 3. Manual/off/auto, 4. Manual/off/auto and high/low.

### Fitted plinth

A plinth, finished black powder coated paint, can be fitted to raise the heater 100mm.

### Fitted isolating valves

DN20 (3/4" BSP) isolating ball valves can be fitted within the casing of Model SA only.

Image 2: Fitted of/off and speed change thermostats



Image 3: Fitted type 1 low-limit thermostats



Image 4: Fitted high/low and manual/off/auto switches



Image 5: Fitted isolating valves - model SA only



Image 6: Fitted plinth





## Performance

Table 2: **Heat outputs**

Heat outputs kW, air volume flow rates l/s, leaving air temperatures °C and hydraulic resistances kPa. Conditions: LTHW 75°C mean, 10K drop across the coil, entering air temperature 18°C.

Figure number	Low speed			Medium speed			High speed			kPa
	kW	l/s	°C	kW	l/s	°C	kW	l/s	°C	
3	1.78	50	47	2.61	75	47	3.19	105	43	0.47
4	3.31	75	54	4.72	115	52	6	160	49	1.67
6	4.51	105	52	6.01	150	51	6.66	180	48	2.6
8	5.66	135	52	8.22	210	50	9.6	270	47	1.29
10	7.85	190	52	9.37	250	49	10.18	290	47	1.65
12	8.68	205	53	11.42	290	50	13.06	360	48	2.71

Table 3: **Correction factors**

Approximate factors for heat output and hydraulic resistance, at various mean water temperatures, entering air temperatures and water temperature drops across the coil.

mean water °C	entering air °C	Temperature drop across coil							
		5K		10K		15K		20K	
		output	hyd.res.	output	hyd.res.	output	hyd.res.	output	hyd.res.
50	18 20	0.55	1.19	0.50	0.28	--	--	--	--
		0.51	1.04	0.46	0.24				
55	18 20	0.65	2.28	0.60	0.38	--	--	--	--
		0.61	1.45	0.56	0.34				
65	18 20	0.85	2.67	0.80	0.65	0.75	0.27	--	--
		0.81	2.44	0.76	0.59	0.71	0.25		
75	18 20	1.05	3.98	1.00	1.00	0.95	0.43	0.91	0.23
		1.00	3.69	0.95	0.92	0.91	0.39	0.87	0.21
85	18 20	--	--	1.20	1.41	1.16	0.62	1.12	0.33
				1.16	1.32	1.11	0.58	1.07	0.32

Table 4:

### Electrical Data

Electrical Data – running and starting currents in amperes, at low, medium and high speeds and motor outputs in Watts.

Figure number	Running current			Starting current	Motor output Watts
	low	med	high		
3	0.17	0.21	0.24	0.45	25
4	0.27	0.31	0.36	0.75	40
6	0.30	0.36	0.41	0.75	40
8	0.43	0.48	0.48	1.15	75
10	0.46	0.47	0.46	1.15	75
12	0.53	0.57	0.53	1.15	75
15	0.56	0.54	0.53	1.15	75

Table 5:

### Coil Capacities

Approximate coil capacities, litre.

Figure number	litre
3	0.63
4	0.77
6	0.77
8	1.03
10	1.03
12	1.25
15	1.25

Table 6:

### Heater Masses

Approximate masses, kg.

Figure number	kg
3	34
4	41
6	43
8	53
10	54
12	65
15	66



### General

Series CM fan convectors are suitable for most applications, where low-level free standing heaters with front discharge and recirculation grilles are desirable.

Having an overall height of only 600mm, Series CM fan convectors are particularly suitable for under sill or under-worktop application, but care should be taken to ensure heaters are sited so that there are no obstructions directly in front, as they could affect air circulation. This is particularly important when using reversed air flow model RA.

Typical applications include: Schools, Colleges, Elderly Peoples' Homes, Libraries, Offices and churches.

### Selection

It is recommended that heaters are selected to operate at medium speed for general use or at low speed for rooms where noise levels are particularly important. Heaters should only be selected at high speed for non critical application, such as entrance foyers, corridors etc. or for initial rapid warm up. Sound power levels are available on request.

From the known heat loss of the room to be heated and the operating conditions, select the model and figure number. For large rooms, it is usually better to select two small heaters, rather than one large, to give better heat distribution and spot noise levels.

Whenever possible, heaters should be located near windows or in areas of disproportionately high heat loss.

By design, Dunham-Bush fan convectors have moderate leaving air temperatures, low outlet velocities and low air throws.

Comfortable conditions throughout the heated space are achieved by good air circulation.

It is recommended that wherever possible, the total volume of the room should be circulated through the sum of the heaters a minimum of three to four times per hour and ideally four to five times per hour.





# Dimensions

Image 7: **Model SA**

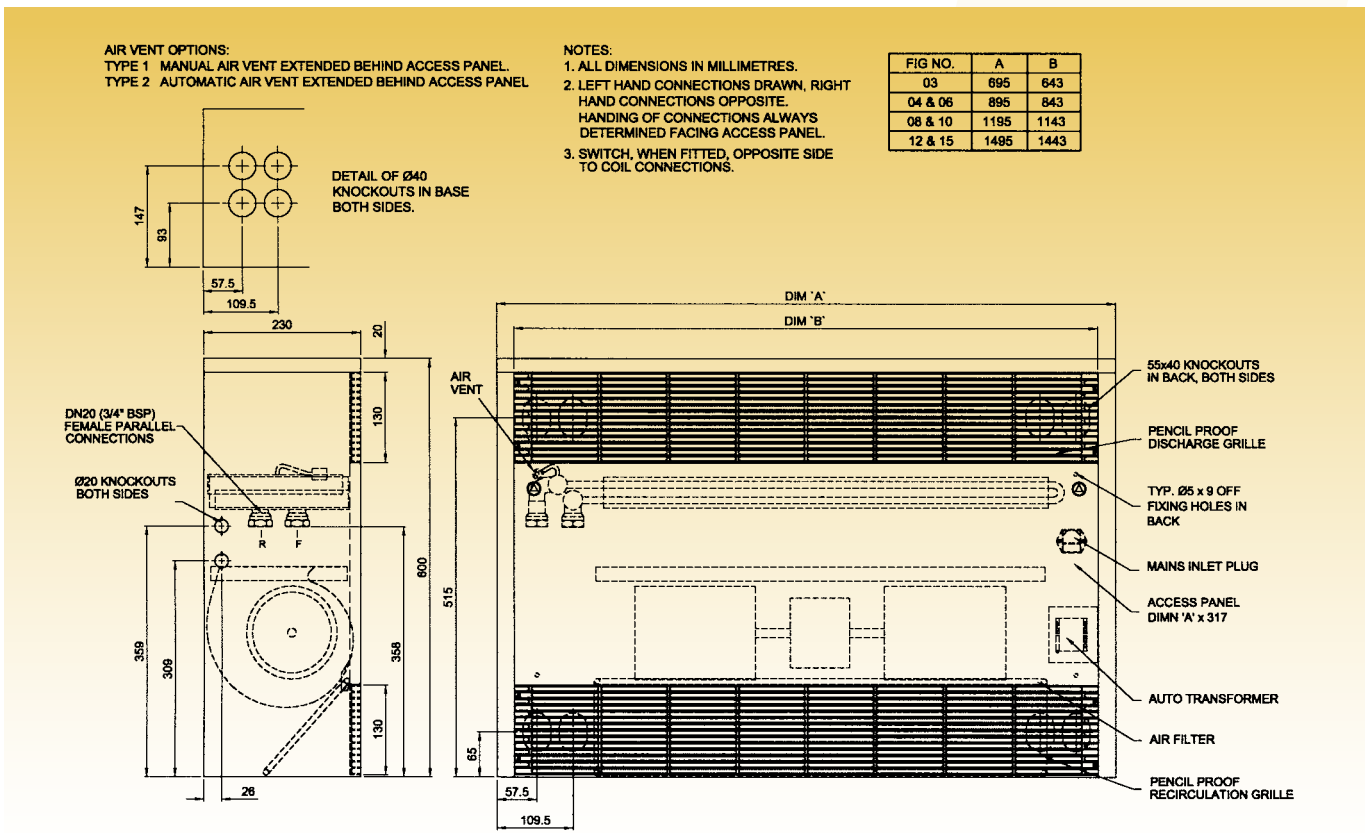
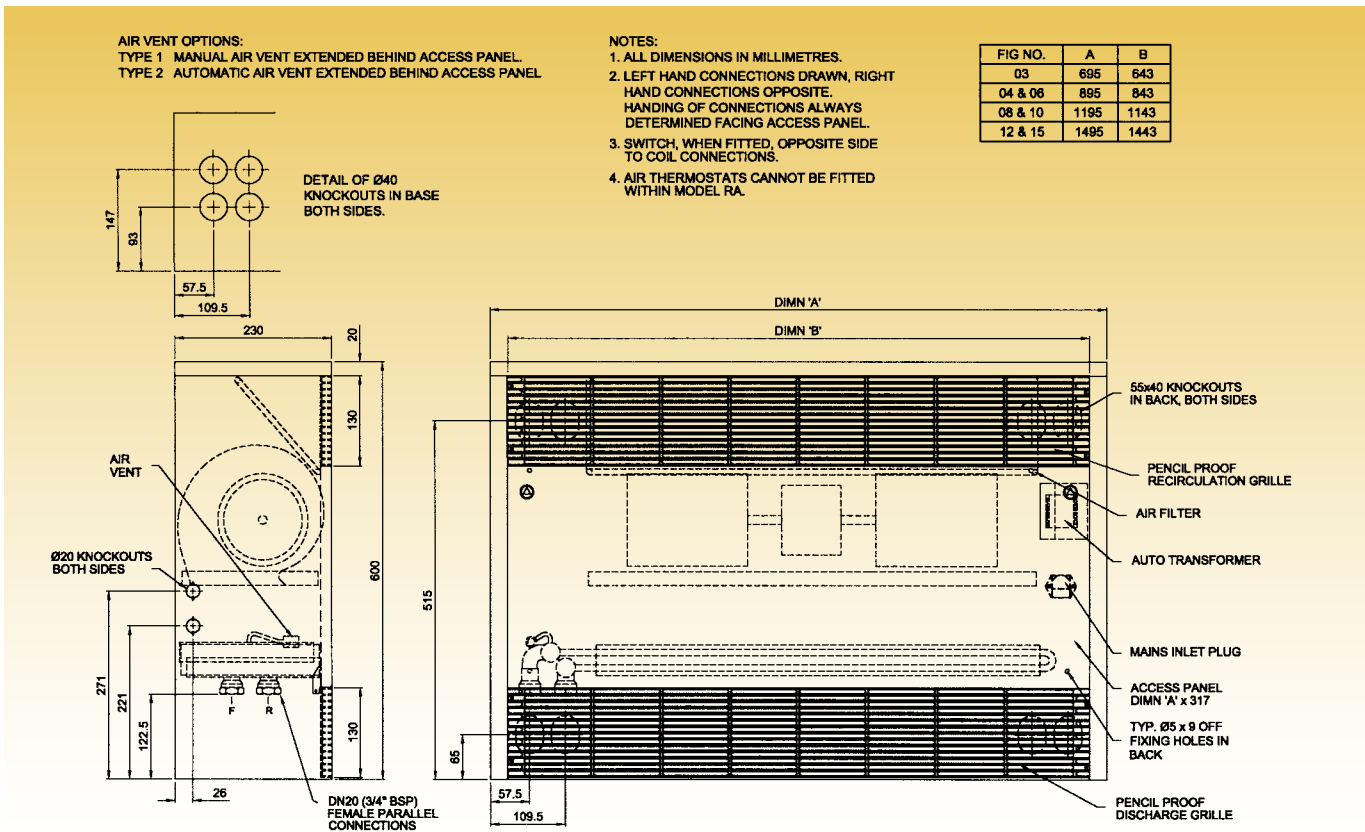

Image 8: **Model RA**





## Engineering Specification

The Series CM fan convector heaters shall be manufactured by Dunham-Bush Limited, Downley Road, Havant, Hampshire, PO9 2JD. The models, figure numbers and quantities shall be as indicated in the schedule and/or on the drawings. The construction of all units must comply with the following specification.

Series CM fan convectors shall be suitable for free-standing application.

**Model SA** – standard air flow, shall have bottom front recirculation grille and top front discharge grille.

**Model RA** – reversed air flow, shall have top front recirculation grille and bottom front discharge grille.

### Casing construction

Casings shall be constructed from 1.2mm mild steel panels, adequately stiffened to minimise distortion. Each casing shall have an access panel secured with locks. The access panel shall be removable within the height of the casing, in order to allow under-worktop installation.

Casings shall be designed to accept pipework and isolating valves. Flattened knockouts shall be provided in the bottom and the back of the casing, for pipework and conduit entry. Side knockouts shall also be provided for conduit entry. When specified, a 100mm high plinth shall be fitted to the bottom of the casing.

### Casing dimensions

Each heater shall have an overall height of 600mm and a width of 230mm. Overall lengths shall be:

- figure 3                      695mm,
- figures 4 and 6            895mm,
- figures 8 and 10          1195mm,
- figures 12 and 15        1495mm.

Casing dimensions shall have a manufacturing tolerance of  $\pm 1$ mm.

### Grilles

Discharge and recirculation grilles shall be pencil proof, manufactured from extruded aluminium alloy section, having 13 louvre blades.

### Heating coil

Coils shall be constructed from 9.35mm O.D. solid drawn copper tubes, expanded into single plate corrugated aluminium fins and brazed to copper headers. Flow and return connections shall be DN20 (3/4 BSP.) female parallel.

Coils less air vents shall be tested to 24 bar gauge.

Each coil shall be provided with either a type 1 manual air vent or type 2 automatic air vent, located behind the access panel. Air vent type shall be as specified.

Table 7:  
**Site test and working pressures – bar gauge**

coils fitted with	cold test pressure	working pressure
type 1 air vent	10.5	7.0
type 2 air vent	9.0	7.0

### Motor/fan platform

Fan/motor platforms shall be manufactured from 1.6mm galvanised steel and shall be fitted with galvanised steel fan housing(s), resiliently mounted motor and centrifugal fan(s). Motor wiring shall be complete with a four-way line connection plug. The platform shall be suspended within the heater casing on resilient channels and shall be easily removable.

### Air filter

Air filters shall be washable, bonded polyester type; filters shall be G2 to BS EN 779 (EU2).





## Construction

### Fan motor

Motors shall be quiet running, resiliently mounted, capacitor start and run, totally enclosed, having class 'B' insulation and rated in accordance with BS5000 part 11. Figure 3 motor shall be 25W, single shaft, all other figure numbers shall be double shaft, figure numbers 4 and 6 shall be 40W, and figure numbers 8, 10, 12 and 15 shall be 75W. Motors shall be wound 230/240 volts, single phase, 50Hertz and shall have 'sealed for life' ball bearings.

### Centrifugal fans

Each fan shall be double inlet, forward curved, statically and dynamically balanced, secured to the fan motor shaft by a grub screw. Figure number 3 shall be provided with one fan, all other figure numbers shall be provided with two fans.

### Electrical connections and wiring

Each heater shall be provided with an I.E.C mains inlet connector, fused 2 amperes, with a spare fuse and an IEC mains inlet plug, located behind the access panel, at the opposite end of the casing to the coil connections. Internal wiring shall be high temperature PVC insulated 16/0.020.

### Auto-transformer

An auto-transformer shall be fitted within the heater casing to provide fan motor speed control. Transformers shall be wired to provide one or two speeds from the range low, medium and high.

### Performance

Series CM fan convectors shall be tested and rated in accordance with BS4856, part1.

### Packaging

Each heater shall be properly packed in a carton, marked with the model and figure number, and any other reference specified on the order for site identification.

### Accessories

If specified, accessories listed in the manufacturers Product Catalogue shall be provided.

### Handling

The purchaser is responsible for off loading. Heaters are individually cartoned and two men can usually handle the heaviest heater. When quantities of heaters are delivered, they may be palletised and shrink wrapped, so a fork lift truck or some form of lifting equipment is desirable. Care should be taken to ensure the heaters are not dropped or knocked under any circumstances.

### Storage

Heaters should be stored under clean, dry conditions. The cartons should not be removed until heaters are required for installation, unless damage in transit is suspected.

**Note** - the purchaser must examine the heaters promptly upon receipt and any claims for damage will only be accepted if at the time of delivery, the consignment note is endorsed with a note detailing the damage and counter signed by the transport driver.

Each heater is marked to show the model, figure number, serial number and any reference given on the order for site identification. This information also appears on the consignment note.

### Preparation

Make proper provision for fixings. The structure to which heaters are to be fixed must be fit for purpose and capable of accepting plugs and screws. A sound flat perpendicular surface and level base are necessary. Heater casings are supplied with knockouts in the bottom and back for pipework and conduit entry.





### **Installation details**

The access panel can only be removed with the key provided. The inner cover, motor/fan platform, pipework cover plate, bottom grille and filter can all be removed to provide better access when making pipework connections.

### **Pipework connections**

Coil connections are DN20 (3/4 BSP.) female parallel. Local Isolating and regulating valves are recommended.

Observe the correct flow and return positions, to ensure the rated heat output.

### **Electrical connections**

A 230/240 Volt, single phase 50 Hertz supply must be connected to the IEC mains inlet plug. Any remote accessories must be connected as show on the wiring diagram supplied with the heater.

Please refer to the Sitework Instructions/ Recommendations supplied with the heater. Additional copies are available on request.

## **Prices & Conditions of Sale**

### **Prices**

Dunham-Bush Ltd do not issue price lists but will be pleased to supply a written quotation upon request.

### **Standard conditions of sale**

The standard conditions of sale appear on all quotation and order acknowledgement forms. Additional copies are available upon request

## **Supply**

### **Availability**

Series CM fan convector heaters are supplied direct from our factory in Havant. The availability varies with demand and should therefore be checked at the time of ordering.

### **Packaging**

Heaters are packed in individual cartons. Each heater is marked to show the model, figure number, serial number and any reference given on the order for site identification. This information also appears on the consignment note.

## **Ordering**

To allow us to process your order promptly, please refer to any quotation we have supplied and any relevant correspondence. Please send your order to our Agent or Sales Engineer who provided the quotation.

There are two ways of providing information necessary for us to supply the required heaters,  
a) please photo copy the fan convector description code form and fill in your requirements or,  
b) please advise the following details:

- 1) Quantity of each model and figure number
- 2) Left or right hand coil connections, as viewed looking at the access panel
- 3) Air vent-manual or automatic
- 4) Fan speed(s)
- 5) Details of any accessories required
- 6) Reference or stencil, for site identification

### **Delivery to Site**

Series CM fan convectors are delivered to site in accordance with our Conditions of Sale. The purchaser is responsible for off-loading and proper safe storage.



## Series CM Fan Convector description code

Code posn	Component	Component description
1	series	CM – fan convector
2	model	SA – standard air flow, RA – reversed air flow
3	figure number	03, 04, 06, 08, 10, 12, 15 – heater size
4	coil connections	L – left hand, R – right hand
5	air vent	M – manual, A – automatic
6	100mm plinth	P – fitted, N – none
7	isolating ball valves	V – fitted, N – none
8	fan speeds	LN–low, MN–med, HN–high, LM–low/med, LH–low/high, MH–med/high
9a	air thermostat on/off	C – capillary fitted, R – remote, N – none
9b	air thermostat high/low	C – capillary fitted, R – remote, N – none
10	low-limit thermostat	1 – fixed setting, 2 – adjustable setting, N – none
11	switch location	E – fitted external, R – remote, N – none
12	switches	1 – on/off, 2 – high/off/low, 3 – man/off/auto, 4 – man/off/auto & high/low, N – none

Fan convector reference	Quantity

Series		Model		Figure number		Conns	Air vent	Plinth	Valves	Fan speed		Air stats		L/L	Switches	
C	M	A										9a	9b	10	11	12
1			2		3	4	5	6	7		8					

- Notes:**
- a) air thermostats and isolating valves cannot be fitted to Model RA
  - b) please select any remote switches and/or thermostats required from the following lists:

Remote switches	Flush mounted part number	Quantity	Surface mounted part number	Quantity
on / off	121-601-010		121-601-001	
high / off / low	121-601-011		121-601-002	
man / off / auto	121-601-012		121-601-003	
man / off / auto & high / low	121-601-015		121-601-006	

Remote room thermostat	Standard user control	Quantity	Tamperproof cover	Quantity
Honeywell T6360B1028	903-002-056		–	
Honeywell T6360B1069	–		903-002-057	



Dunham-Bush operates a quality control system and is a company of assessed capability to BS EN ISO 9001 : 2000

Whatever the product, wherever its eventual destination, Dunham-Bush will have ensured that it has been designed to a high technical standard, manufactured with care and assembled to our strict quality control policies and procedures.

## Product support

In the United Kingdom and Ireland, Dunham-Bush have a network of sales agents and representatives, situated at strategic locations, to provide local support in pricing and selection. Further technical and application support is available at the Dunham-Bush office and factory in Havant.

## Other Dunham-Bush products

Series AM Fan Convectors  
Series BM Fan Convectors  
Series L Fan Convectors  
'Avant-Garde' Fan Convectors

Evolution Radiant Panels  
Evo-Lite Radiant Panels  
Dunham Strip Radiant Panels

Series F Fan Coil Units  
Panther Fan Coil Units  
Cougar Fan Coil Units  
Leopard Fan Coil Units  
Puma Fan Coil Units  
Lynx Fan Coil Units  
Jaguar Fan Coil Units

Voidpak Air Handling Units  
Air Handling Units  
Series UH Unit Heaters  
Warmsafe LST Radiators

Sentry Air Curtain

Packaged Chillers

Finvector Perimeter Heating  
Hydrocourse Trench Heating



Manufacturer reserves the right to change any product specification without notice

*Dunham-Bush Ltd  
Downley Road  
Havant  
Hants PO9 2JD*

*Tel. 023 9247 7700*

*Fax. 023 9245 0396*

*Email*

*info@dunham-bush.co.uk*

*www.dunham-bush.co.uk*